

32T System Integration

Roger Cappallo
MIT Haystack Observatory
Canberra Meeting
2009.1.21

Two Phases of Integration

- * establishing end to end operation in the lab at Haystack
- * integration of the complete system on site at Boolardy
- * differences:
 - * 1 vs. 4 receivers and 1 vs. 12 fibres
 - * single data path vs. full width processing
 - * test software vs. operational software
 - * lab PC vs. RTC (of some form)

32T Digital Architecture

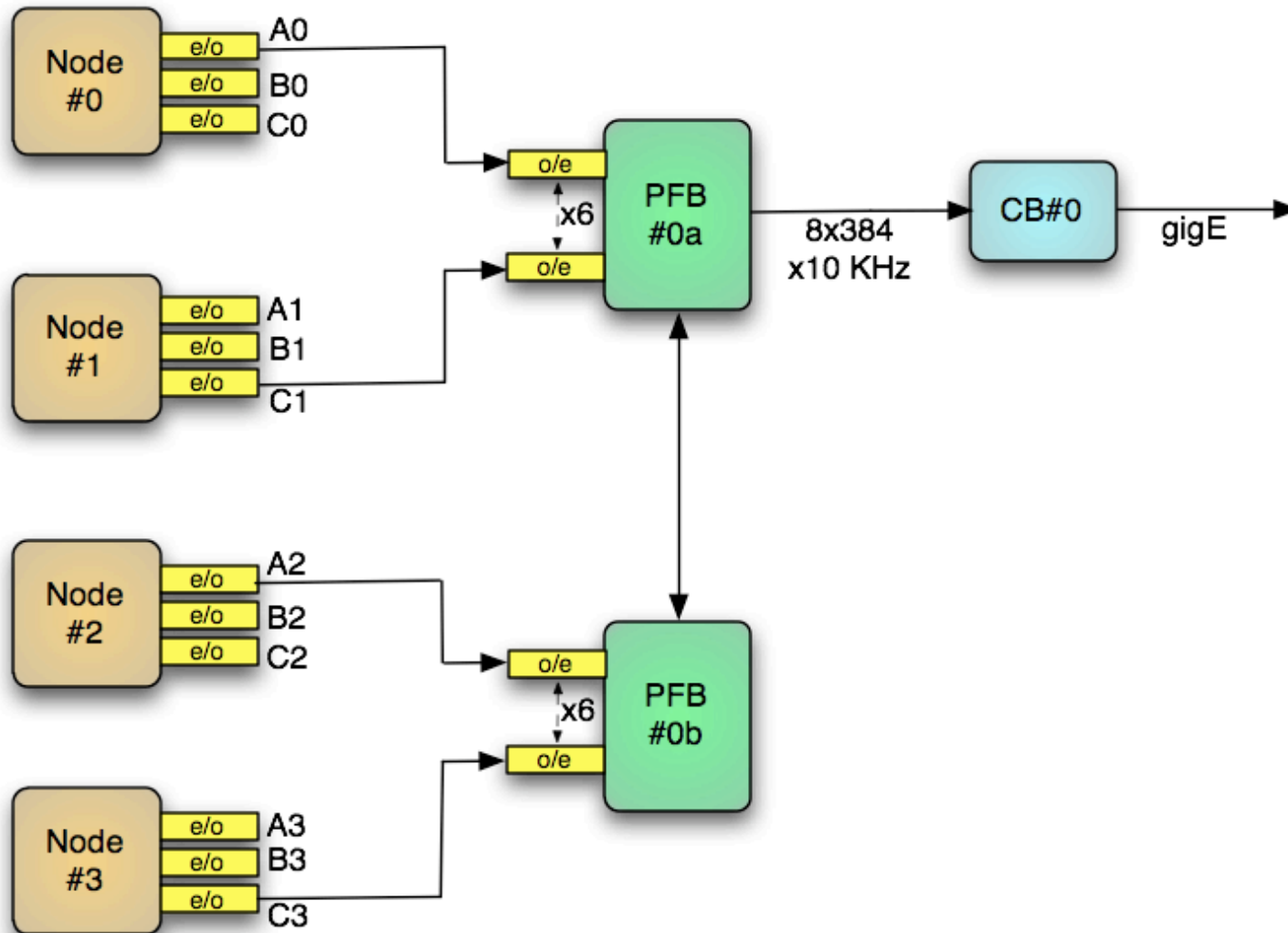

Data Path for Integration at Haystack

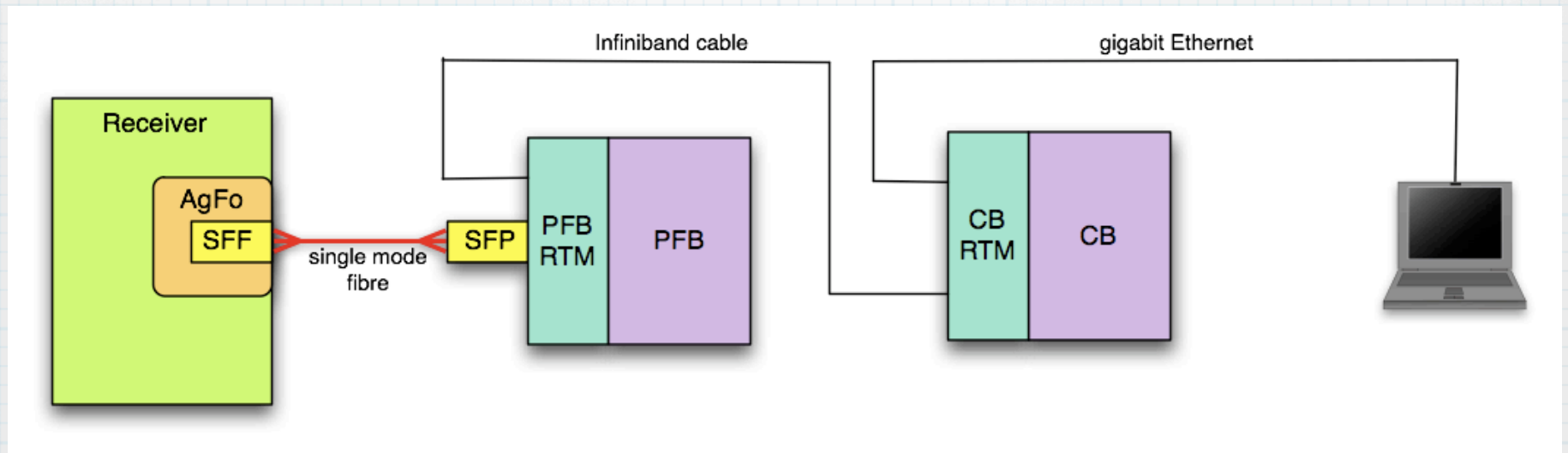

Receiver to PFB

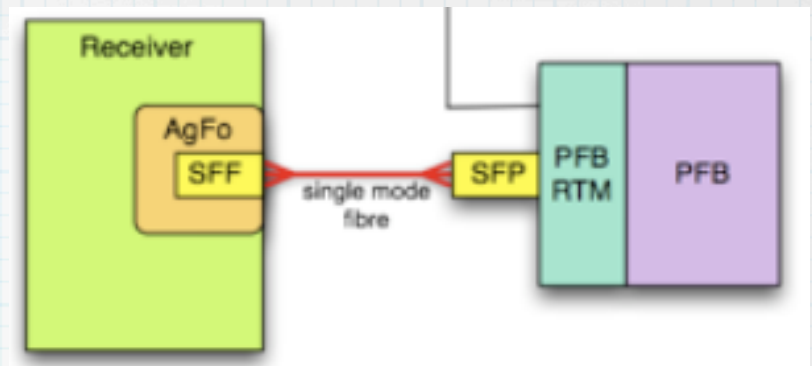

* Elements:

- * AgFo packet formation
- * SFF fibre transmission (Finisar FTLF1421)
- * SFP dual Rx reception (untested - Gennum G02920)
- * new (untested) PFB RTM
- * packet reception on PFB board
- * Deepak Kumar at RRI has successfully transmitted and received packets from AgFo to AgFo over 3 km of fibre
- * Russell McWhirter has this task

PFB to CB

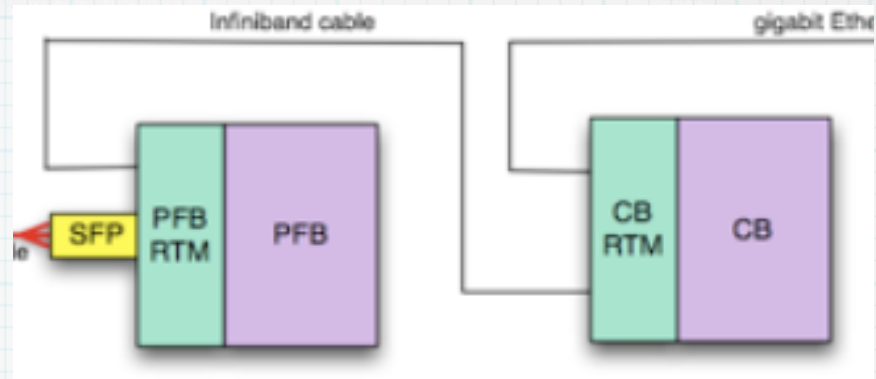

- * Elements:
 - * Packet generation code on PFB
 - * PFB RTM to CB RTM on Infiniband cable
 - * Packet reception and verification by way of correlator code on CB
- * Small step beyond CB loop-back test
- * Bart Kincaid & Russ McWhirter share task

CB to PC

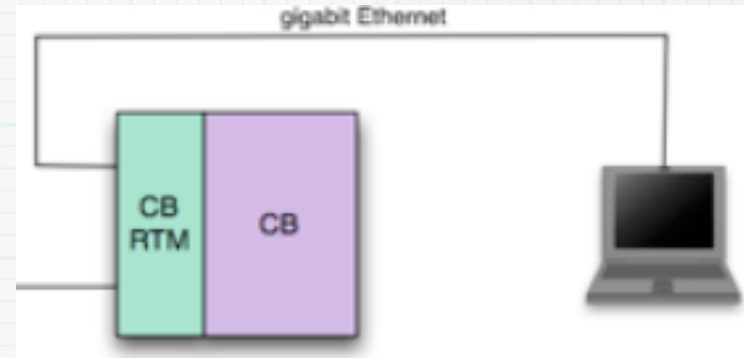

- * gigE to an Ubuntu PC capturing data to RAM or disk
- * data rate is 477 Mb/s
- * compared to software model of result
- * tasked to Bart Kincaid and Roger Cappallo

Additional Integration at Haystack

- * full internal parallel paths of PFB and CB tested via signal replication
- * testing with operational (field) software
- * integration with RTC system (if possible)
- * verify all optical input paths working
- * simultaneous e2e from dipole to RTC **may** be achievable before the Rx returns to site

Datapath Integration Status

* Receiver to PFB

- * waiting for Rx (en route from ANU to Haystack)
- * waiting for PFB (to be shipped from CSIRO, now that the Rocket I/O problem is fixed)
- * waiting for Deepak's packet test code from RRI

* PFB to CB

- * waiting for PFB
- * awaiting completion of CB loopback test

* CB to PC

- * will proceed after CB firmware check out

Onsite Integration of Full 32T

- * single ATCA cage with PFB, CB, 2 RTM's
- * reconfigure power supply for 240V
- * first tests of multiple fibres into PFB
- * other elements of 32T system previously rung out using software correlator!
- * circa April 2009